

[®]
JETPRIME

THROTTLE CONTROL WITH INTEGRATED HANDLEBAR SWITCH

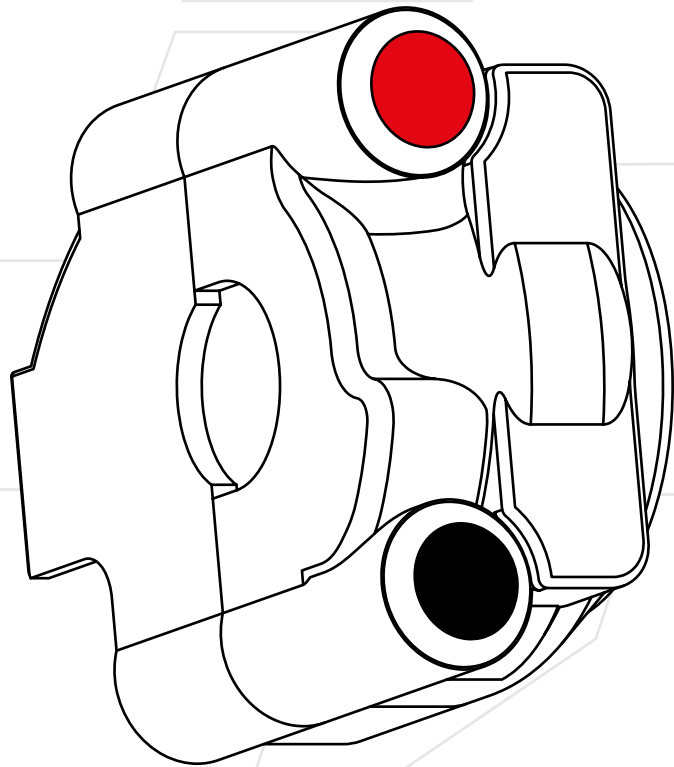

Ref. JP ACC 600

TECHNICAL FEATURES

- CNC-machined anodized aluminium body
- stronger and lighter than the original part
- IP69K protection
- laser engraving
- wired with RAYCHEM 105° cable and sealed with RAYCHEM S1125 resin

INSTALLATION

This product is plug-and-play, no modification is required on the bike:

1. make sure the ignition is turned off
2. disconnect and remove the original right handlebar switch (refer to the manufacturer's workshop manual)
3. disconnect the electronic throttle wiring
4. open and remove the original throttle housing
5. install the JETPRIME throttle control housing on the electronic throttle using the provided bolts, and tighten to 10 Nm
6. connect the wiring to the original connectors

NOTE

This throttle control is designed for racing, and is specific to bikes equipped with a **Mectronik** control unit.
It cannot be used on a stock bike.

FUNCTIONS

1. ON/OFF
2. START

NOTE

This is a RACING handlebar switch.
It is specifically designed for track use and includes only the essential functions needed for racing.

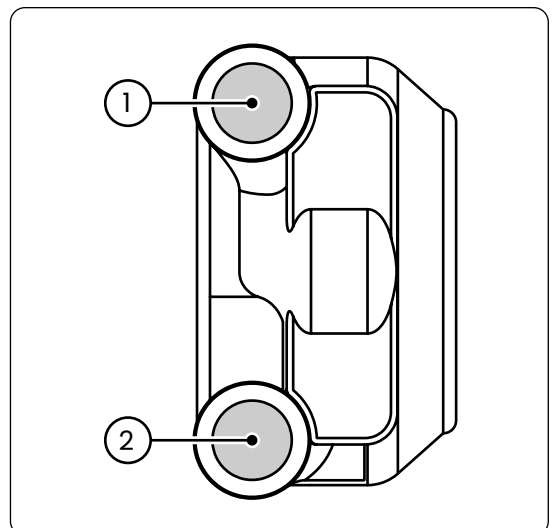



JETPRIME S.R.L.

Via Eugenio Montale, 1
41016 Novi di Modena - Rovereto sulla Secchia (MO)
Phone: +39 059 672223 - Email: info@jetprime.it

www.jetprimeshop.it

All JETPRIME products are designed for racing use only and should be installed by an expert.

The manufacturer, importer, or dealer shall not be liable for any damage caused by improper installation or operation of the JETPRIME product.

The warranty is limited to defects recognized by our technical department and to normal use. The warranty is void in case of accident, modification, improper or racing use.

Do not install the product on a motorcycle for which it was not designed or tested by JETPRIME.

The technical specifications of JETPRIME products and related products are subject to change without notice.