

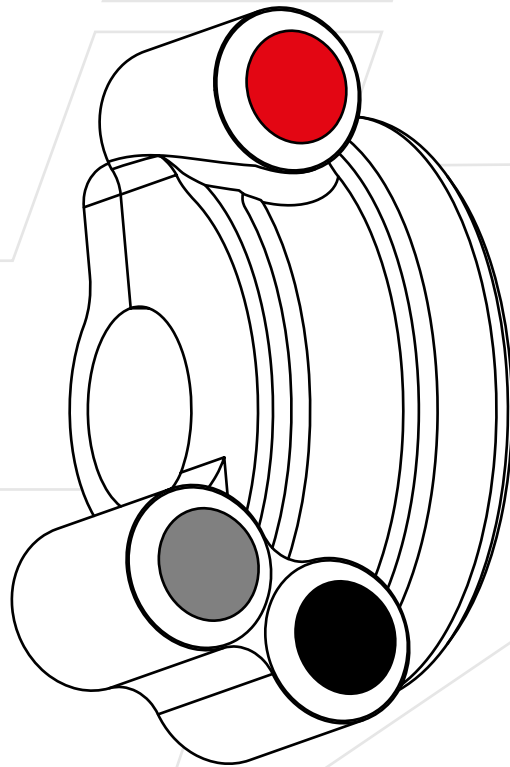

# ***THROTTLE CONTROL WITH INTEGRATED HANDLEBAR SWITCH***



*Ref. JP ACC 026*

## TECHNICAL FEATURES

---

- CNC-machined anodized aluminium body
- stronger and lighter than the original part
- IP69K protection
- laser engraving
- wired with RAYCHEM 105° cable and sealed with RAYCHEM S1125 resin

## INSTALLATION

---

This product is plug-and-play, no modification is required on the bike:

1. make sure the ignition is turned off
2. open the original throttle housing and disconnect the throttle cables from the throttle tube (refer to the manufacturer's workshop manual)
3. disconnect the wiring and remove the throttle housing
4. insert the throttle cables through the back of the JETPRIME throttle control housing, and connect them to the throttle tube
5. close the throttle control housing around the handlebar and tighten the bolts to 10 Nm
6. check the throttle cable play and adjust it if needed
7. connect the wiring to the original connectors

## FUNCTIONS

---

1. ON/OFF
2. MODE
3. START

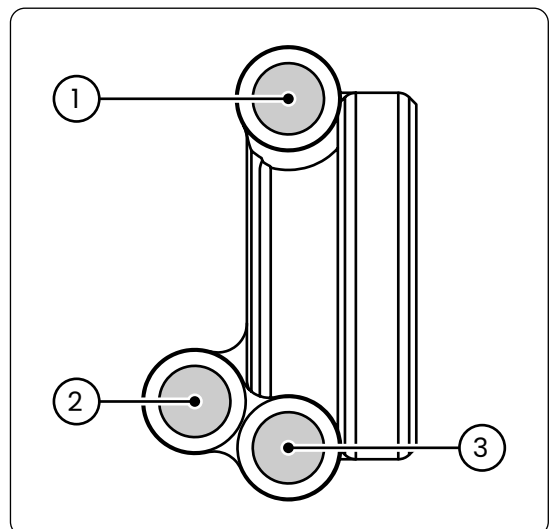



**JETPRIME S.R.L.**

Via Eugenio Montale, 1  
41016 Novi di Modena - Rovereto sulla Secchia (MO)  
Phone: +39 059 672223 - Email: [info@jetprime.it](mailto:info@jetprime.it)

**[www.jetprimeshop.it](http://www.jetprimeshop.it)**

All JETPRIME products are designed for racing use only and should be installed by an expert.

The manufacturer, importer, or dealer shall not be liable for any damage caused by improper installation or operation of the JETPRIME product.

The warranty is limited to defects recognized by our technical department and to normal use. The warranty is void in case of accident, modification, improper or racing use.

Do not install the product on a motorcycle for which it was not designed or tested by JETPRIME.

The technical specifications of JETPRIME products and related products are subject to change without notice.